

TST-VALVE Y-PATTERN STRAINER

JIS-10K FLANGE END

CF61 CAST IRON FC20

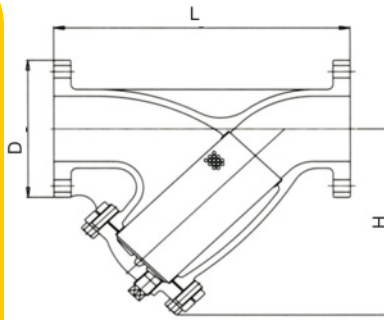

WORKING PRESSURE	
WATER.OIL.GAS UNDER 120°C	10.0 kg f/cm ²
TEST PRESSURE	
SHELL	20.0 kg f/cm ²
PART	MATERIAL
BODY	CAST IRON (FC20)
BONNET	CAST IRON (FC20)
SCREEN	STAINLESS STEEL (SUS304)
GASKET	ASBESTOS
PLUG	STEEL(SS41)

DIMENSIONS

SIZE	in	2"	2 1/2"	3"	4"	5"	6"	8"	10"	12"	14"	16"
	mm	50	65	80	100	125	150	200	250	300	350	400
L		220	270	290	350	390	440	540	640	805	910	1000
H		128	188	200	240	250	300	410	475	600	668	760
D		155	175	185	210	250	280	330	400	445	490	560

TST-VALVE FOOT VALVE

JIS-10K FLANGE END

CF71 CAST IRON FC20

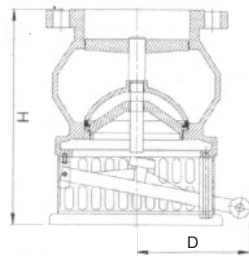

WORKING PRESSURE	
NON-SHOCK WATER UNDER 120°C	10.0 kg f/cm ²
TEST PRESSURE	
SHELL	20.0 kg f/cm ²
SEAT	15.0 kg f/cm ²
PART	MATERIAL
MAINBODY	CAST IRON (FC20)
UPPER SEAT	DUCTILE IRON (FCD45)
SHAFT	BRASS (C3771)
DISC	DUCTILE IRON (FCD45)
SEALING	BY FLUID
SEAM	BRASS (C3771)
SCREEN	STAINLESS STEEL (SUS304)
CLEAN LEVER	DUCTILE IRON (FCD45)
LEVER STAND	DUCTILE IRON (FCD45)

DIMENSIONS

SIZE	in	2"	2 1/2"	3"	4"	5"	6"	8"
	mm	50	65	80	100	125	150	200
H (mm)		160	165	210	215	240	275	380
D (mm)		95	105	115	125	145	160	185

TST-VALVE GATE VALVE (RISING STEM)

JIS-16K FLANGE END

DF12 DUCTILE IRON FCD-45

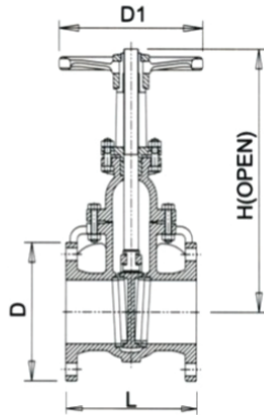

WORKING PRESSURE	
NON-SHOCK WATER UNDER 120°C	16.0 kg f/cm ²

TEST PRESSURE	
SHELL	32.0 kg f/cm ²
SEAT	24.0 kg f/cm ²

PART	MATERIAL
BODY	DUCTILE IRON (FCD45)
BONNET	DUCTILE IRON (FCD45)
DISC	DUCTILE IRON (FCD45)
SEAT RING	STAINLESS STEEL (SCS13)
STEM	STAINLESS STEEL (304)
PACKING	ASBESTOS
HANDWHEEL	CAST IRON (FC20)

DIMENSIONS

SIZE	in	2"	2 1/2"	3"	4"	5"	6"	8"	10"	12"	14"	16"
	mm	50	65	80	100	125	150	200	250	300	350	400
L		178	190	203	229	254	267	292	330	350	381	406
H		345	385	460	545	677	730	1002	1150	1340	1515	1780
D1		180	180	204	210	250	265	355	395	490	490	600
D		155	175	200	225	270	305	350	430	480	540	605

TST-VALVE SWING CHECK VALVE

JIS-16K FLANGE END

DF51 DUCTILE IRON FCD-45

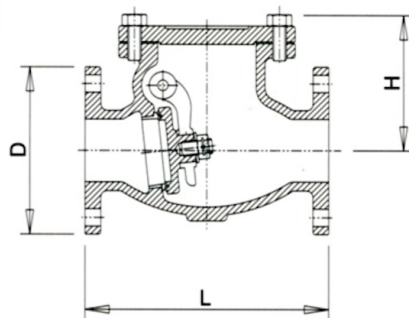

WORKING PRESSURE	
NON-SHOCK WATER UNDER 120°C	16.0 kg f/cm ²

TEST PRESSURE	
SHELL	32.0 kg f/cm ²
SEAT	24.0 kg f/cm ²

PART	MATERIAL
BODY	DUCTILE IRON (FCD45)
BONNET	DUCTILE IRON (FCD45)
DISC	DUCTILE IRON (FCD45)
SEAT RING	CAST BRONZE (BC-6)
PLUG	STEEL (SS41)
HINGE PIN	STAINLESS STEEL (410)
GASKET	ASBESTOS

DIMENSIONS

SIZE	in	2"	2 1/2"	3"	4"	5"	6"	8"	10"	12"
	mm	50	65	80	100	125	150	200	250	300
L		203	220	241	292	330	356	495	622	698
H		105	115	140	155	170	190	246	283	330
D		155	175	185	210	250	280	330	400	445