

TST-VALVE GATE VALVE (NON-RISING STEM)

JIS-10K

FLANGE END

CF11 CAST IRON FC20

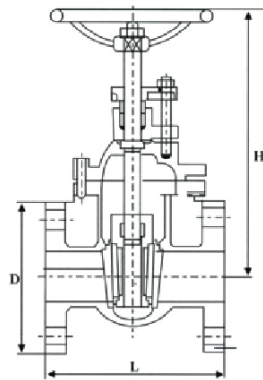

WORKING PRESSURE	
PULSE WATER. OIL.GAS UNDER 200°C	10.0 kg f/cm ²
TEST PRESSURE	
SHELL	20.0 kg f/cm ²
SEAT	15.0 kg f/cm ²
PART	MATERIAL
BODY	CAST IRON (FC20)
BONNET	CAST IRON (FC20)
STEM	STAINLESS STEEL (SUS410)
DISC	CAST IRON (FC20)
SEAT RING	CAST BRONZE/STAINLESS STEEL (B62/SUS304)
GLAND	DUCTILE IRON (FCD45)
PACKING	NOT ASBESTOS
HANDWHEEL	CAST IRON (FC20)

DIMENSIONS

SIZE	in	2"	2 1/2"	3"	4"	5"	6"	8"	10"	12"
	mm	50	65	80	100	125	150	200	250	300
L	180	190	200	230	250	270	290	330	350	350
H	252	280	290	380	420	455	575	686	782	782
D	155	175	185	210	250	280	330	400	445	445

TST-VALVE GATE VALVE (RISING STEM)

JIS-10K

FLANGE END

CF12 CAST IRON FC20

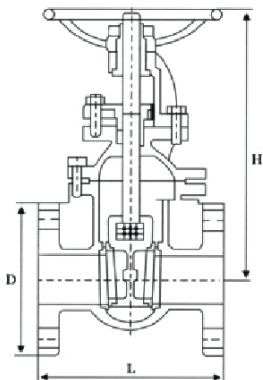

WORKING PRESSURE	
PULSE WATER. OIL.GAS UNDER 200°C	10.0 kg f/cm ²
TEST PRESSURE	
SHELL	20.0 kg f/cm ²
SEAT	15.0 kg f/cm ²
PART	MATERIAL
BODY	CAST IRON (FC20)
BONNET	CAST IRON (FC20)
STEM	STAINLESS STEEL (SUS410)
DISC	CAST IRON (FC20)
SEAT RING	CAST BRONZE/STAINLESS STEEL (B62/SUS304)
GLAND	DUCTILE IRON (FCD45)
PACKING	NOT ASBESTOS
HANDWHEEL	CAST IRON (FC20)

DIMENSIONS

SIZE	in	2"	2 1/2"	3"	4"	5"	6"	8"	10"	12"
	mm	50	65	80	100	125	150	200	250	300
L	180	190	200	230	250	270	290	330	350	350
H	267	280	300	405	460	560	705	880	1100	1100
D	155	175	185	210	250	280	330	400	445	445

TST-VALVE SILENT CHECK VALVE

JIS-16K

SCREWED END

BS53 FORGED BRASS

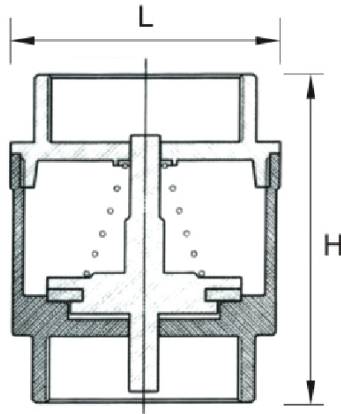

WORKING PRESSURE	
NON-SHOCK WATER UNDER 120°C 16.0 kg f/cm ²	
TEST PRESSURE	
SHELL	32.0 kg f/cm ²
SEAT	24.0 kg f/cm ²
PART	MATERIAL
BODY	FORGED BRASS
TRAY	PA
SEAT	NBR
SPRING	STAINLESS STEEL
STEM	PA
END PIECE	FORGED BRASS

DIMENSIONS

SIZE	in	1/2"	3/4"	1"	1 1/4"	1 1/2"	2"	2 1/2"	3"
	mm	15	20	25	32	40	50	65	80
L		32	39	48	57	67	81	108	126
H		53	39	67	78	84	98	115	130

TST-VALVE Y-PATTERN STRAINER

JIS-16K

SCREWED END

BS61 FORGED BRASS

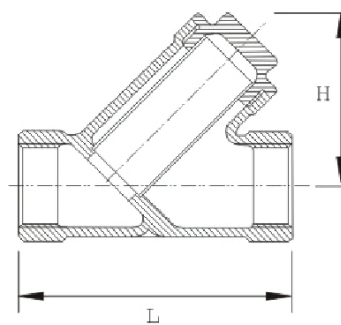

WORKING PRESSURE	
WATER. OIL.GAS UNDER 120°C 16.0 kg f/cm ²	
TEST PRESSURE	
SHELL	32.0 kg f/cm ²
PART	MATERIAL
BODY	FORGED BRASS
CAP	FORGED BRASS
STRAINER	STAINLESS STEEL
PLUG	FORGED BRASS
GASKET	PTFE

DIMENSIONS

SIZE	in	1/2"	3/4"	1"	1 1/4"	1 1/2"	2"	2 1/2"	3"
	mm	15	20	25	32	40	50	65	80
L		56	66	76	97	112	126	141	151
H		39	44	50	62	74	91	107	115